

VELVETLight
MADE TO LAST

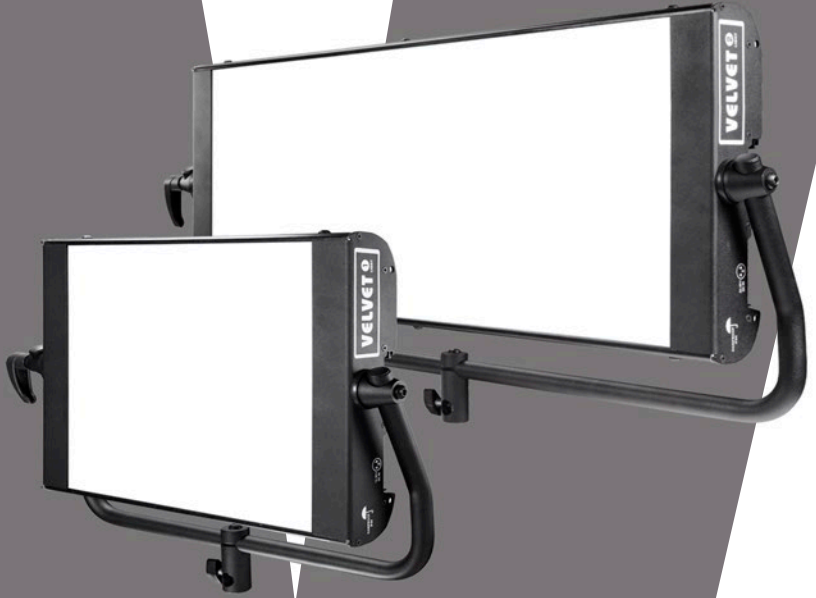

RAINPROOF SUPERSOFT PANELS

VELVET Light 1/2

SERIES USER MANUAL

THELIGHT®

This guide provides information about how to use the product functions to illuminate with this equipment as well as warnings on his use.

These are products of professional use for exterior and interior locations or studio and must be operated only by qualified technical personnel.

To obtain the maximum features, please read the following operating instructions very carefully before using this fixture for the first time. Please keep these operating instructions for you and subsequent users to reference in the future.

THELIGHT Luminary for cine and TV, S.L.

SAFETY PRECAUTIONS	For your own safety, please read and follow all safety instructions and warnings.
EXEMPTION FROM Liability	THELIGHT Luminary for cinema and TV, S.L. does not assume any responsibility for lighting failures caused by malfunction of this product. The manufacturer disclaims liability for any damage to persons or property caused by inappropriate operation, damage of this kind lies in the responsibility of the operator.
WARRANTY	This product is manufactured to local specifications and the warranty is valid within the country of purchase. Should the product fail or malfunction while you are abroad, the manufacturer assumes no responsibility for servicing the product locally or bearing the expenditure incurred thereof.

www.thelight.com.es

The total or partial reproduction of this guide is prohibited without the express written permission of THELIGHT.

THELIGHT technology is protected under Spanish license laws with international patents pending.

Information and specifications in this document are subject to change without notice.

2017 © Copyright THELIGHT. All rights reserved.

Various symbols are used throughout this instruction manual and on the product to prevent physical harm to you or other people and damage to property.

The symbols and their meanings are explained below.



Possible risk of injury or damage to equipment

Do not attempt to open any of the device or component housings. To reduce the risk of electric shock, do not remove LED panel side covers or front plastic diffuser. No user-serviceable parts inside. Maintenance and repair work to be carried out only by THELIGHT Service Centre.

Do not cover the aluminium lamp head heat sink while using it. Proper ventilation must be provided. Avoid exposing the lamp head to the heat radiation of other light fixtures.

The lamp head is equipped with mid power LED. Due to their high light-output intensity don't stare directly into the light source



This symbol indicates the risk of electric shock or fire danger that could result in injury or damage to equipment.

In order to protect against risk of electric shock, the installation should be properly grounded. Defeating the purpose of the grounding type plug will expose you to the risk of electric shock.



This equipment has been checked and meets the requirements of general safety for electronic devices. These requirements are specified to provide a reasonable protection against electromagnetic interferences when the equipment is used in commercial environments.

This equipment generates, uses and can emit waves of radio frequency, and if not properly used following the instructions of this manual can produce interferences in radio communications. The use of this equipment in residential areas can produce interference, the user will be the only responsible of correcting them.



Though the light generated by LED does not produce any heat, for what his use turns out to be very comfortable for the actors, the lamp head acts as a heat sink through its back part.

Surface can reach a temperature between the 20 °C and the 60 °C. Please use protective gloves if you touch the lamp head at the heat sink.

06	MAIN FEATURES
07	MODELS
08	ACCESSORIES/ POWER OPTIONS
11	ACCESORIES/ BEAM CONTROL & DMX CONTROL
13	ACCESORIES/ BAGS & CASES
14	VELVET Light 1 SPECIFICATIONS & PARTS POWER OPTIONS
17	VELVET Light 1 STUDIO SPECIFICATIONS & PARTS POWER OPTIONS
19	VELVET Light 2 SPECIFICATIONS & PARTS POWER OPTIONS
22	VELVET Light 2 STUDIO SPECIFICATIONS & PARTS POWER OPTIONS
24	PLACING INTO OPERATION YOKE TO LED PANEL ASSEMBLING VELVET Light 1 & 2 MOUNTING OPTIONS, SECURITY CABLES
26	DIGITAL ADJUSTMENTS/ COLOR & DIMMING
27	DIGITAL ADJUSTMENTS/ MASTER & SLAVE
28	DIGITAL ADJUSTMENTS/ DMX RDM FUNCTIONS
29	ACCESSORIES INSTALLATION/ SNAPGRID & HEXAGONAL SPUD
30	CHROMACITY COORDINATES DIAGRAM
31	REGULATIONS
32	DIAGRAMS VELVET Light SERIES 1 & 2 LOCATION
33	DIAGRAMS VELVET Light SERIES 1 & 2 STUDIO
34	WARRANTY

VELVET Light 1 / 2 LOCATION

RAINPROOF IP-54/DMX x 1 XLR-5

VELVET Light 1 / 2 STUDIO

DUSTPROOF IP-51/DMX x 2 XLR-5



VELVET Light series are LED panels housing Osram mid power LED. They had been specially designed and their colorimetry calibrated for professional photography, cinematography and television industry use.



- Rainproof robust aluminum construction
- Variable Color Temperature from 2700K to 6500K
- Dedicated quick-access button 32K / 56K
- Mid-power Osram LED 50,000 hours life
- +95 CRI digitally calibrated light
- Professional and consistent color rendition
- Digital control and through DMX RDM
- Silent fan-free operation
- Flicker free up to 3,000 fps
- Soft shadow-less light
- Smooth dimming with no color shift

NOTE ABOUT MEASURING COLOUR TEMPERATURE (CCT)

VELVET Light incorporate the innovative THELIGHT technology based on Osram mid power LED precise bin selection + optical diffuser + CPU control software to obtain the wide range of calibrated colour temperatures combined with a high color rendering index CCT.

We must remark that traditional color meters still in use today are designed for a full spectrum source such as incandescent lights and therefore cannot be used to accurately read the correlated color temperature (CCT) of the light emitted by THELIGHT and other LED light fixtures.

The eventual diversions to green display as CC05M or CC10M in hand-held color meters are due to these unaccuracy on reading of the light emitted by LED and must not be considered.

To precisely measure the light emitted by THELIGHT and other LED light fixtures a spectrometer specially calibrated for LED sources must be used.

THELIGHT guarantees pure white light with no green deviation and correct colorimetry of the light delivered by its VELVET LED luminaries which have been calibrated in laboratory according to CIE 13.3-1995 international standards for measurement of the CRI and chromatic coordinates (x, and CIE-1931).

The reliability of this digital equipment is supported by the calibration THELIGHT has made in laboratory by spectrophotometer, which precision is half-yearly calibrated according to the National Institute of Standards (NIST) of the United States and of the Physikalisch-Technische Bundesanstalt (PTB) of Germany.

In order that the advanced THELIGHT luminaries could be used together with other light sources, THELIGHT has accurately calibrated both the CCT and the chromatic coordinates to match them with traditional light sources following tungsten and daylight standards.

Square 1x1 foot (30 x 30 cms) and rectangular 2x1 feet (30 x 60 cms) rainproof LED panels made of aluminum housing OSRAM high CRI selected BIN LED.

Every VELVET Light LED panel includes a digital control on board. The range of VELVET Light 1 and 2 products is composed by:

VELVET Light 1

RAINPROOF IP54
Ref VL1-IP54



VELVET Light 1 STUDIO

DUSTPROOF IP51
Ref VL1-STUDIO



VELVET Light 2

RAINPROOF IP54
Ref VL2-IP54

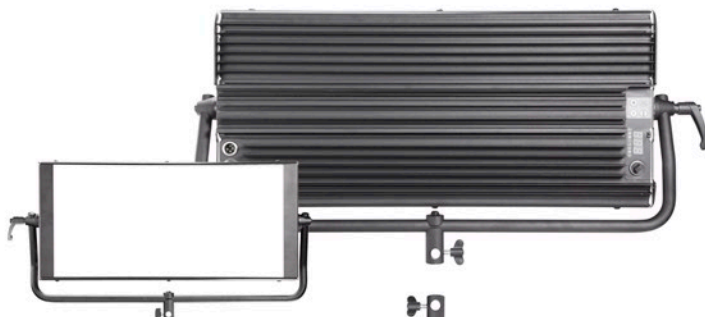

VELVET Light 2 STUDIO

DUSTPROOF IP51
Ref VL2-STUDIO

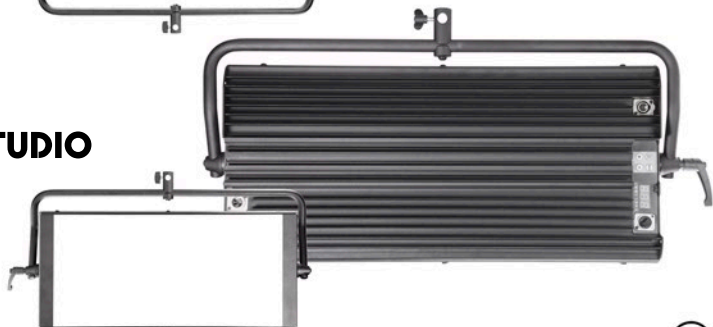

VELVET Light 1

LOCATION

120W AC power adapter with XLR3 connector + quick mount + power cable + hexagonal spud
Ref. VL-PSU-120W



VELVET Light 1

STUDIO

120W STUDIO AC power adapter with XLR3 connector + quick mount + power cable with PowerCon connector
Ref. VL1-PSU-STUDIO



VELVET Light 2

LOCATION

180W AC power adapter with XLR3 connector + quick mount + power cable + hexagonal spud
Ref. VL-PSU-180W



VELVET Light 2

STUDIO

185W STUDIO AC power adapter with XLR3 connector + quick mount + power cable with PowerCon connector
Ref. VL2-PSU-STUDIO



VELVET Light 1

LOCATION

Vlock battery mount with XLR-3 connector
on quick link plate + Spud
Ref VL1-Vlock



VELVET Light 1

LOCATION

Gold battery mount with XLR-3 connector
on quick link plate + Spud
Ref VL1-Gold



VELVET Light 2

LOCATION

Vlock battery mount 2x with XLR-3 connector
+ Spud
Ref VL2-Vlock



VELVET Light 2

LOCATION

Gold battery mount 2x with XLR-3 connector
+ Spud
Ref VL2-Gold

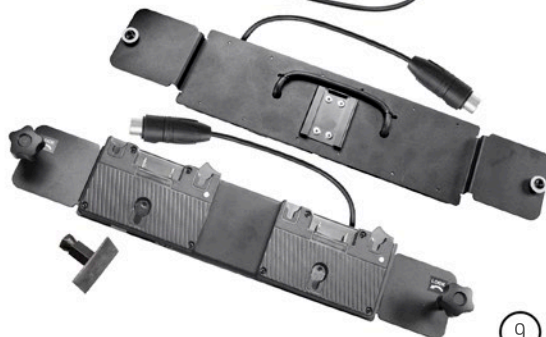

VELVET Panels

4,5 m XLR-3 DC power
extension cable
Ref DCC4.5-XLR3



VELVET Panels

DMX Remote control XLR-5
Ref VL-RC



VELVET Light 1/2 LOCATION

DMX Aerial splitter IN/OUT
Ref THE-VL-DMXinout



VELVET Light 1/2 SERIES

VELVET 2 center ball head with
16mm baby receiver
Ref. VL2-QLS



VELVET Light 1/2 SERIES

Pole Operated Yoke
Ref VL1-Y-Poleop (for VELVET Light 1)
Ref VL2-Y-Poleop (for VELVET Light 2)



VELVET Light 1 SERIES

Removable Barndoors
Ref VL1-RB



VELVET Light 2 SERIES

Removable Barndoors
Ref VL2-RB



VELVET Light 1 SERIES

Foldable Snapgrid 40°
Ref VL1-SGrid



VELVET Light 2 SERIES

Foldable Snapgrid 40°
Ref VL2-SGrid

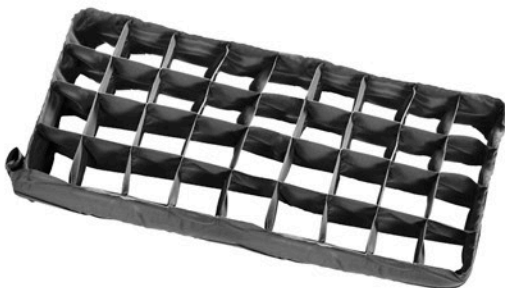

VELVET Light 1 SERIES

Semi rigid Cordura carrying bag for
1x VELVET Light 1/ Power 1 kit
Ref VL1-Bag



VELVET Light 1 SERIES

Semi rigid Cordura carrying bag for
2x VELVET Light 1/ Power 1 kits
Ref VL1x2-Bag



VELVET Light 2 SERIES

Semi rigid Cordura carrying bag for
1x VELVET Light 2/ Power 2 kit
Ref VL2-Bag



VELVET Light 1/2 SERIES

Hard Flight case
Ref VL1-Case
(for 1x VELVET Light 1/ Power 1 kit)
Ref VL2-Case
(for 1x VELVET Light 2/ Power 2 kit)

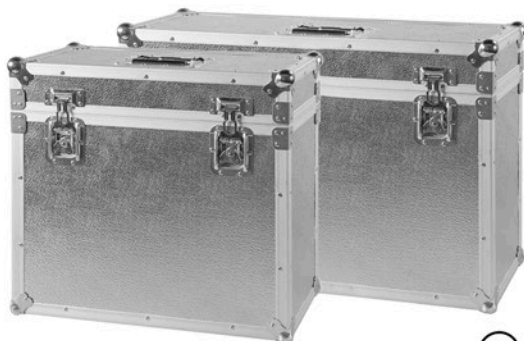

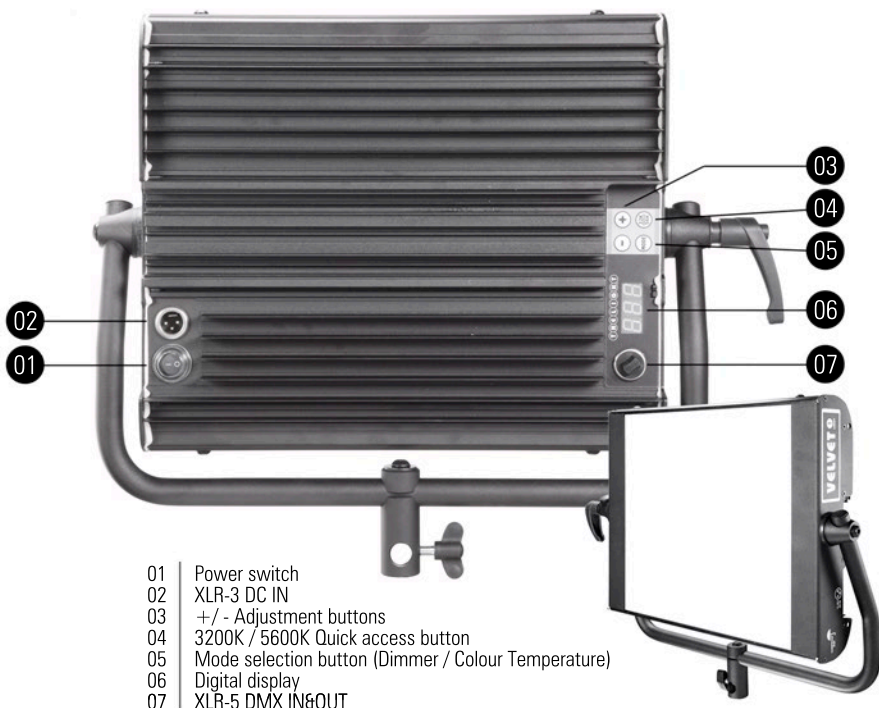

- | | |
|----|---|
| 01 | Power switch |
| 02 | XLR-3 DC IN |
| 03 | +/- Adjustment buttons |
| 04 | 3200K / 5600K Quick access button |
| 05 | Mode selection button (Dimmer / Colour Temperature) |
| 06 | Digital display |
| 07 | XLR-5 DMX IN&OUT |

COLOUR TEMPERATURE	Adjustable from 2700K a 6500K (100K increments)
LIGHT INTENSITY	Dimmable 0 to 100 (smooth and flicker-free)
COLOR RENDERING INDEX	95 CRI
TLCI	95 TLCI
DIMENSIONS	370 x 308 x 68 mm / 14,5 x 12 x 2,7" (panel)
WEIGHT	3,5 kgs / 7,7 lbs (panel)
POWER DRAW	75 W / 0,68 Amps at 110 VAC
POWER SUPPLY	12-35V DC.
BEAM ANGLE	Vlock or Gold battery mounts, 90-264V AC 50/60Hz
	100°

PHOTOMETRICS	1700 lux / 157 fc at 1m / 3 feet
	210 lux / 19 fc at 3m / 10 feet

LED RATED LIFE	More than 50.000
POWER CONNECTION	XLR-3 DC IN connector + PSU or Vlock, Gold battery mounts
OUTPUT FREQUENCY	16KHz (Flicker-free up to 3000 fps)
OPERATION TEMPERATURE	From -20°C to +40°C
COOLING	No-noise, fan-free passive cooling
PROTECTION	IP54 RAINPROOF, indoor or outdoor use
VELVET LED TECHNOLOGY	OSRAM selected BIN LED core unit + optic diffuser + CPU software control
RIGGING OPTIONS	Aluminum yoke with 16 baby receiver combined with 28 junior pin, four sliding threads 1/4" for riggings located on panel side, Pole operated Yoke, Quick Link Swivel ball head.
QUICK MOUNTING ACCESSORIES	AC power supply, Vlock or Gold battery adapters, DMX 512 splitter cable I&O, foldable Snaggrid, removable barn doors, Cordura Soft bag, Hard Flight case.
CONSTRUCTION & FINISH	Black anodized extruded aluminum and black powder coated sheet aluminum

BATTERY POWER
12 to 35 VDC

Connect any battery from 12 to 35 VDC to the XLR3 connector located at the back of the panel.



When powering VELVET from an external battery through the XLR3 connector check the proper polarity as shown in the picture at the side of the panel.

To ensure maximum performance of the equipment use only high-load capacity batteries with a high continuous draw meaning a Discharge Current of at least 7A.

BATTERY POWER
Vlock or Gold Battery

Insert the Vlock plate by sliding it into the slot located at the back of the panel.

Insert and extract the plate from the right hand of the panel where the digital display is located.

Connect the XLR3 to the connector located on the back of the panel.

**DANGER**

Secure the Power supply plate by turning the locking knob anti clockwise

To avoid electric shocks and/or damages in the equipment the power switch located at the back of the LED panel must be off before connecting or disconnecting cables.

AC POWER
90 to 264 VAC

Insert the Power supply plate by sliding it into the slot located at the back of the panel.

Insert and extract the plate from the right hand of the panel where the digital display is located.



Connect the XLR3 to the connector located under the power switch.
Connect the power cable to the plug located in the side of the power supply and the power plug with a mains power outlet.

**DANGER**

Secure the Power supply plate by turning the locking knob anti clockwise

To avoid electric shocks and/or damages in the equipment the power switch located at the back of the LED panel must be off before connecting or disconnecting cables.

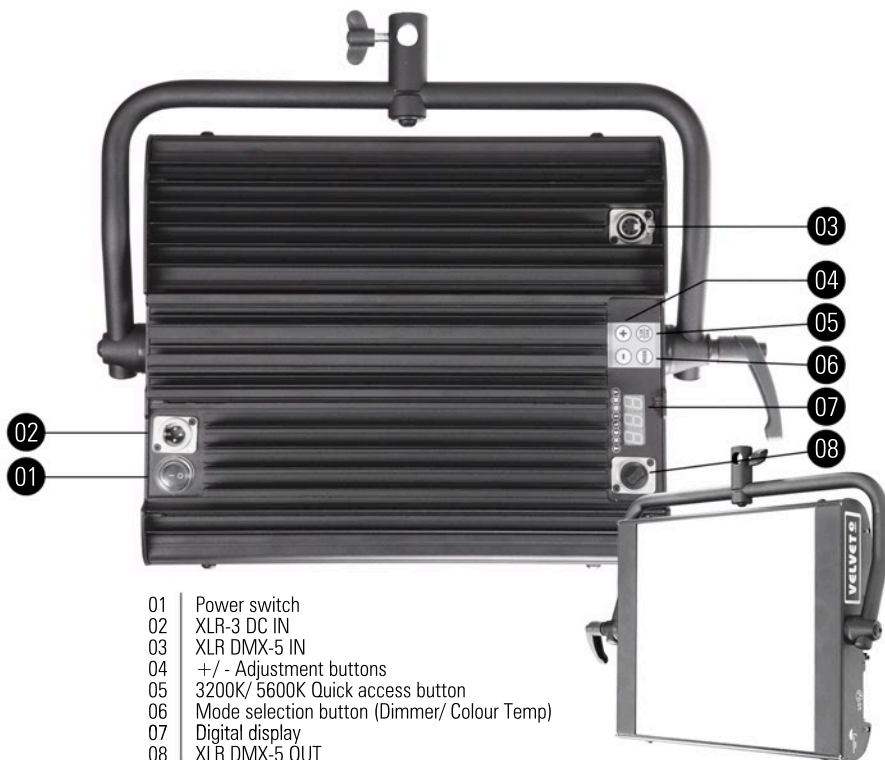

- | | |
|----|---|
| 01 | Power switch |
| 02 | XLR-3 DC IN |
| 03 | XLR DMX-5 IN |
| 04 | +/- Adjustment buttons |
| 05 | 3200K/ 5600K Quick access button |
| 06 | Mode selection button (Dimmer/ Colour Temp) |
| 07 | Digital display |
| 08 | XLR DMX-5 OUT |

COLOUR TEMPERATURE	Adjustable from 2700K a 6500K (100K increments)
LIGHT INTENSITY	Dimmable 0 to 100 (smooth and flicker-free)
COLOR RENDERING INDEX	95 CRI
TLCI	95 TLCI
DIMENSIONS	370 x 308 x 68 mm / 14,5 x 12 x 2,7" (panel)
WEIGHT	3,5 kgs / 7,7 lbs (panel)
POWER DRAW	75 W / 0,68 Amps at 110 VAC
POWER SUPPLY	90-264 VAC, 50/60Hz

BEAM ANGLE 100°

PHOTOMETRICS 1700 lux / 157 fc at 1m / 3 feet
210 lux / 19 fc at 3m / 10 feet

LED RATED LIFE	More than 50.000
POWER CONNECTION	XLR-3 DC IN connector
OUTPUT FREQUENCY	16KHz (Flicker-free up to 3000 fps)
OPERATION TEMPERATURE	From -20°C to +40°C
COOLING	No-noise, fan-free passive cooling
PROTECTION	IP51 DUSTPROOF, indoor or outdoor use
VELVET LED TECHNOLOGY	OSRAM selected BIN LED core unit + optic diffuser + CPU software control
RIGGING OPTIONS	Aluminum yoke with 16 baby receiver combined with 28 junior pin, four sliding threads 1/4" for riggings located on panel side, Pole operated Yoke, Quick Link Swivel ball head.
QUICK MOUNTING ACCESSORIES	AC power supply, Zfoldable Snapgrid, removable barn doors, Cordura Soft bag, Hard Flight case.
CONSTRUCTION & FINISH	Black anodized extruded aluminum and black powder coated sheet aluminum

AC POWER 90 to 264 VAC



Insert the Power supply plate by sliding it into the slot located at the back of the panel.

Insert and extract the plate from the right hand of the panel where the digital display is located.

Connect the XLR3 to the connector located under the power switch. Connect the power cable to the plug located in the side of the power supply and the power plug with a mains power outlet.



DANGER

Secure the Power supply plate by turning the locking knob anti clockwise

To avoid electric shocks and/or damages in the equipment the power switch located at the back of the LED panel must be off before connecting or disconnecting cables.

VELVET Light 2 LOCATION

SPECIFICATIONS



- | | |
|----|---|
| 01 | Power switch |
| 02 | XLR-3 DC IN |
| 03 | +/- Adjustment buttons |
| 04 | 3200K/ 5600K Quick access button |
| 05 | Mode selection button (Dimmer/ Colour Temp) |
| 06 | Digital display |
| 07 | XLR-5 DMX IN&OUT |

COLOUR TEMPERATURE	Adjustable from 2700K a 6500K (100K increments)
LIGHT INTENSITY	Dimmable 0 to 100 (smooth and flicker-free)
COLOR RENDERING INDEX	95 CRI
TLCI	95 TLCI
DIMENSIONS	670 x 308 x 68 mm / 26 x 12 x 2,7" (panel)
WEIGHT	6 kgs / 13,2 lbs (panel)
POWER DRAW	150 W / 1,36 Amps at 110 VAC
POWER SUPPLY	24-35V DC via XLR-3 Double Vlock or Gold battery mount 90-264V AC, 50/60Hz

BEAM ANGLE

100°

PHOTOMETRICS3600 lux / 334 fc at 1m / 3 feet
450 lux / 42 fc at 3m / 10 feet**LED RATED LIFE**

More than 50.000

POWER CONNECTION

XLR-3 DC IN connector

OUTPUT FREQUENCY

16KHz (Flicker-free up to 3000 fps)

OPERATION TEMPERATURE

From -20°C to +40°C

COOLING

No-noise, fan-free passive cooling

PROTECTION

IP54 RAINPROOF, indoor or outdoor use

VELVET LED TECHNOLOGY

OSRAM selected BIN LED core unit + optic diffuser + CPU software control

RIGGING OPTIONS

Aluminum yoke with 16 baby receiver combined with 28 junior pin, four sliding threads 1/4" for riggings located on panel side, Pole operated Yoke, Quick Link Swivel ball head.

QUICK MOUNTING ACCESSORIES

AC power supply, Vlock or Gold battery adapters, DMX 512 splitter cable I&O, foldable Snapgrid, removable barn doors, Cordura Soft bag, Hard Flight case.

CONSTRUCTION & FINISH

Black anodized extruded aluminum and black powder coated sheet aluminum

BATTERY POWER
24 to 35 VDC

Connect any battery from 24 to 35 VDC to the XLR3 connector located at the back of the panel



When powering VELVET from an external battery through the XLR3 connector check the proper polarity as shown in the picture at the side of the panel.

To ensure maximum performance of the equipment use only high-load capacity batteries with a high continuous draw meaning a Discharge Current of at least 7A.

BATTERY POWER
Double Vlock or Gold
Battery

VELVET Light 2 can also be powered with two Vlock or Gold batteries to double the running time.

Insert the VELVET 2 double Vlock plate by sliding it into the slot located at the back of the panel.

Insert and extract the plate from the right hand of the panel where the digital display is located

**DANGER**

VELVET 2 panel exclusively runs when two Vlock (or Gold Mount) batteries are inserted on the mounts.

Secure the Power supply plate by turning the locking knob anti clockwise

To avoid electric shocks and/or damages in the equipment the power switch located at the back of the LED panel must be off before connecting or disconnecting cables.

AC POWER
90 to 264 VAC

Insert the Power supply plate by sliding it into the slot located at the back of the panel.

Insert and extract the plate from the right hand of the panel where the digital display is located.



Connect the XLR3 to the connector located under the power switch.

Connect the power cable to the plug located in the side of the power supply and the power plug with a mains power outlet.

**DANGER**

Secure the Power supply plate by turning the locking knob anti clockwise

To avoid electric shocks and/or damages in the equipment the power switch located at the back of the LED panel must be off before connecting or disconnecting cables.

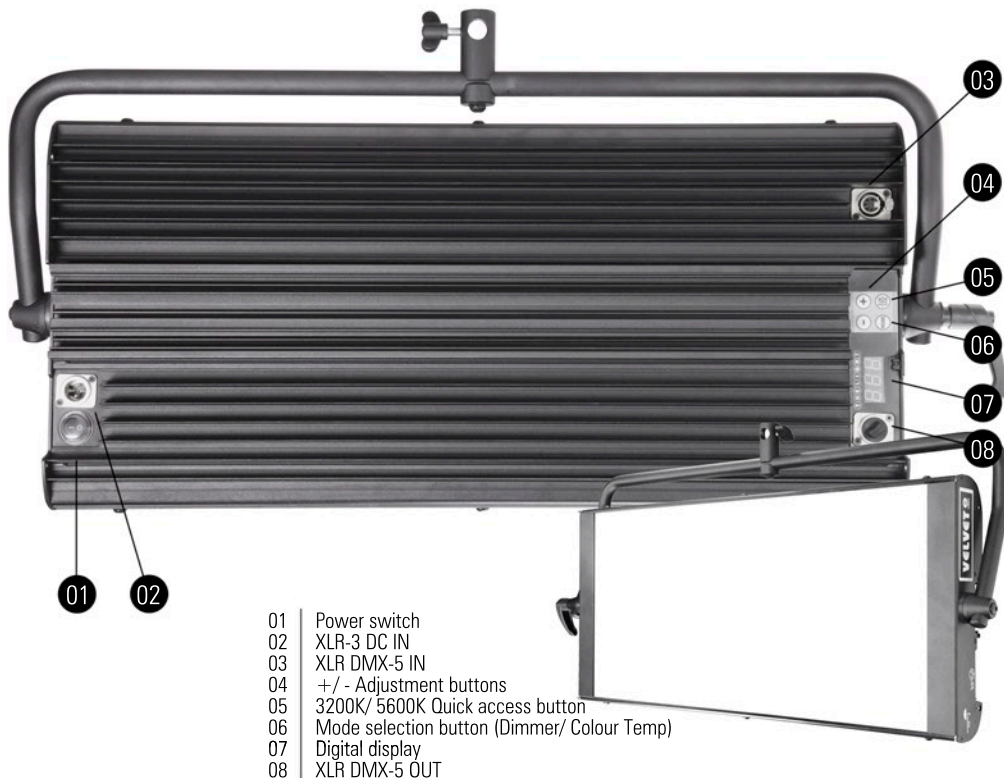

01	Power switch
02	XLR-3 DC IN
03	XLR DMX-5 IN
04	+/- Adjustment buttons
05	3200K/ 5600K Quick access button
06	Mode selection button (Dimmer/ Colour Temp)
07	Digital display
08	XLR DMX-5 OUT

COLOUR TEMPERATURE	Adjustable from 2700K a 6500K (100K increments)
LIGHT INTENSITY	Dimmable 0 to 100 (smooth and flicker-free)
COLOR RENDERING INDEX	95 CRI
TLCI	95 TLCI
DIMENSIONS	670 x 308 x 68 mm / 26 x 12 x 2,7" (panel)
WEIGHT	6 kgs / 13,2 lbs (panel)
POWER DRAW	150 W / 1,36 Amps at 110 VAC
POWER SUPPLY	90-264 VAC, 50/60Hz

BEAM ANGLE 100°

PHOTOMETRICS 3600 lux / 334 fc at 1m / 3 feet
450 lux / 42 fc at 3m / 10 feet

LED RATED LIFE	More than 50.000
POWER CONNECTION	XLR-3 DC IN connector
OUTPUT FREQUENCY	16KHz (Flicker-free up to 3000 fps)
OPERATION TEMPERATURE	From -20°C to +40°C
COOLING	No-noise, fan-free passive cooling
PROTECTION	IP51 DUSTPROOF, indoor or outdoor use

VELVET LED TECHNOLOGY OSRAM selected BIN LED core unit + optic diffuser + CPU software control

RIGGING OPTIONS Aluminum yoke with 16 baby receiver combined with 28 junior pin, four sliding threads 1/4" for riggings located on panel side, Pole operated Yoke, Quick Link Swivel ball head.

QUICK MOUNTING ACCESSORIES AC power supply, Zfoldable Snapgrid, removable barn doors, Cordura Soft bag, Hard Flight case.

CONSTRUCTION & FINISH Black anodized extruded aluminum and black powder coated sheet aluminum

AC POWER
90 to 264 VAC

Insert the Power supply plate by sliding it into the slot located at the back of the panel.

Insert and extract the plate from the right hand of the panel where the digital display is located.

Connect the XLR3 to the connector located under the power switch.
Connect the power cable to the plug located in the side of the power supply and the power plug with a mains power outlet.

**DANGER**

Secure the Power supply plate by turning the locking knob anti clockwise

To avoid electric shocks and/or damages in the equipment the power switch located at the back of the LED panel must be off before connecting or disconnecting cables.

PLACING INTO OPERATION/YOKE INSTALLATION

YOKE TO PANEL
assembling

Align the adjustable Yoke with the VELVET Lightt 1/2 panel as shown in the picture.



Assemble the Yoke to the LED panel by using the mounting kit of bolts, washers and adjustable handle. First mount the handles with the metric M8 metal washer then insert the thick rubber washers between the Yoke and the LED panel.

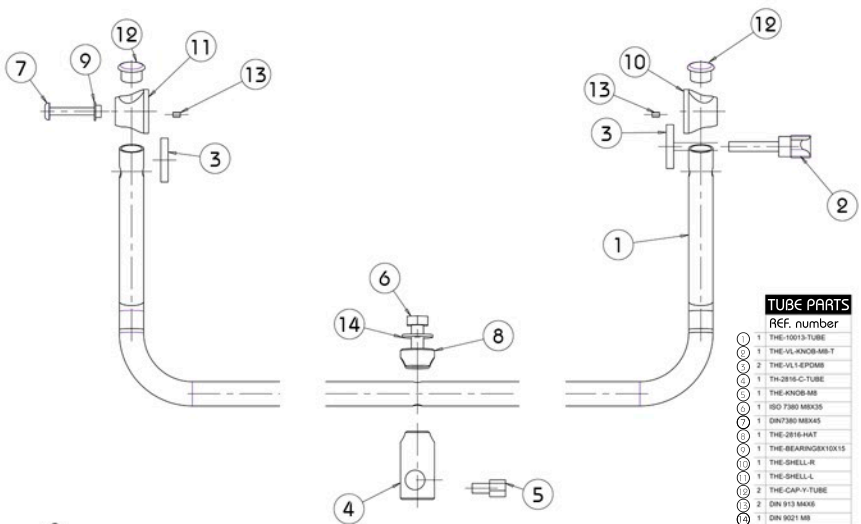

WARNING

It is mandatory to mount the rubber washers (tube parts 3) between the Yoke and the panel to warranty the rainproof IP54 in LOCATION models.

PLACING INTO OPERATION/MOUNTING & SECURITY

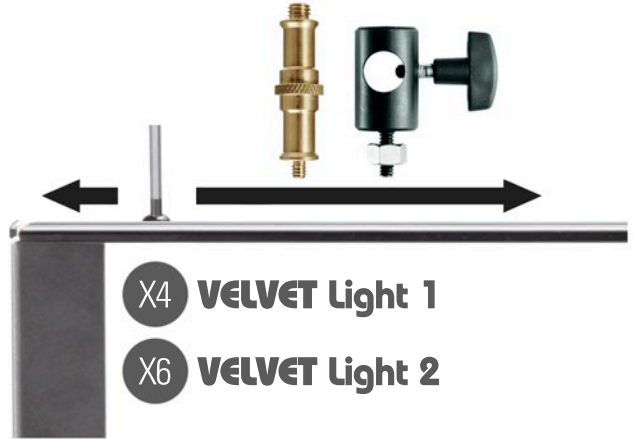

MOUNTING OPTIONS

VELVET Light panels have been designed to be easily installed and hidden on tight locations or low ceiling rooms.

They can be rigged up in many ways through the adjustable yoke, swivel ball head or by using the sliding 1/4-20" threads and bolts located on both top and bottom of any VELVET panel.



SECURITY CABLES

The LED panel is provided with several holes specially design to insert one or more snaps and their safety cable.



WARNING

When a VELVET panel and any other component is mounted in a hanging position it must be secured with a safety cable rated at a minimum of ten times the weight of the light fixture including its accessories.

DIGITAL ADJUSTMENTS/COLOR & DIMMING

POWER ON/OFF Turn on the equipment by switching on the power button. The light settings always remain stored when the digital control is powered off. By pushing the MODE button you can select either Color temperature or Dimmer adjustment. The digital control enables to adjust the following light parameters through its programmed CPU:

- Calibrated Color Temperature variation
- Stable colour dimming

COLOR TEMPERATURE variation VELVET Light includes a dedicated button to immediately set 3200K or 5600K. Color temperature can also be increased or reduced through the +/- buttons located at the digital control panel. The display indicates either the selected color temperature or the dimming value. When Color temperature is selected a dot "." appears between the two digits value. The value 3.2 corresponds to 3200K and the value 3.3 to 3300K and so on.



Push the "+" button to increase color temperature or push the "-" button to decrease it. If you keep pushed any of the buttons you will get a fast continuous variation. Every push on the buttons will increase or decrease the color temperature in increments of 100 Kelvin.

DIMMER intensity variation The dimmer is totally digital and guarantees the regulation of light intensity with minimal changes in the selected color temperature. Light intensity can be easily increased or reduced through the +/- buttons located at the digital control panel. The display indicates the selected dimmer value from 1 to 100. Push the + button to increase light intensity or push the - button to decrease it. If you keep pushed any of the buttons the you will get a fast continuous variation.



DIGITAL ADJUSTMENTS/MASTER & SLAVE

**MASTER-SLAVE
function**

The integrated Master-slave function allows to link an array of any VELVET LIGHT products together and operate them all without a controller. The first VELVET fixture will be the Master acting as the controller and all the others will react and copy the color temperature and dimmer values. Use DMX XLR-5 in&out splitter cables (ref. THE-VL-DMXinout) to daisy chain several VELVET panels. Any VELVET Light, Power or MINI can be mixed in the same chain because they are fully compatible.

To make the first unit as the Master follow this steps:

- 01 Switch off the power button
- 02 Push "+" and "--" buttons at the same time and then switch on the power button
- 03 Now the unit is in DMX mode and any DMX channel can be addressed
- 04 Push the "--" button until "n n t" will be shown in the display



- 05 Push "32K/56K" button to confirm the MASTER mode
- 06 A dot will permanently blink on the display reminding that the panel is set as MASTER

NOTE Every time you switch off the power button the VELVET panels are automatically set to SLAVE mode



WARNING

Only the first VELVET panel on the chain can be the Master. Every other VELVET panels must be set on standard Slave mode and address at channel 001.



WARNING

The VELVET panel set as MASTER cannot control any other lighting fixture out of VELVET Light, Power or MINI not even other THELIGHT articulated products.

DMX RDM control

VELVET fixtures have been designed for a full bi-directional DMX RDM control from the 5-pin DMX port located at the back of the fixture. Once the DMX controller is powered ON a dot "." appears in the right down corner of the digital display as DMX operation status reminder.



Use DMX XLR-5 in&out splitter cables (ref. THE-VL-DMXinout) to daisy chain several VELVET non STUDIO panels or mix them within any DMX line of different fixtures.

ADDRESSING CHANNELS

To address the DMX channel on any VELVET panel follow this steps:
Switch off the power button

- 01 Push "+" and "--" buttons at the same time and then switch on the power
 - 02 button.
 - 03 Now the unit is in DMX mode and any DMX channel can be addressed
 - 04 Push the "+" or "--" buttons to increase or decrease the first fixture
 - 05 address.
- Once you have chosen the desired address number push the "32K/56K" button to save the selection.

Keep in mind the following points regarding DMX control:

- VELVET DMX protocol uses 2 channels per fixture
- After the DMX address is entered the fixture will automatically assign the following channel
- If you wish to control several VELVET fixtures at the same values you will have to set them to the same address
- If you wish to control several VELVET fixtures independently you will have to offset their address by 2 channels. Example
fixture1 address 001 -- fixture2 address 003 -- fixture3 address 005

DMX CHANNELS

When you connect your console to VELVET you will be able to control the fixtures through 2 channels:

- CH01 START ADDRESS**
CH02 START ADDRESS+1

COLOUR TEMPERATURE From 2.7 to 6.5 (from 2700Kelvin to 6500Kelvin)
Fader=0 (2.7) means 2700Kelvin / Fader=100 (6.5) means 6500Kelvin
DIMMER

NOTES

Do not use microphone cables or other general purpose two-core cables designed for audio or signal use. They are not suitable for DMX 512. Problems due to wrong cabling may not be immediately perceptible. Microphone cables may appear to work fine, but systems built with such cables may fail or be susceptible to random errors. Cable must comply with RS-485 DMX protocol (EIA485).

A DMX terminator should be plugged into the final, empty, OUT connector of the last slave on the daisy chain. A terminator is a stand-alone male connector with a built-in 120 Ω resistor, matching the cable characteristic impedance, connected across the primary data signal pair.

ACCESORIES INSTALLATION

SNAPGRID installation

Position the VELVET panel with the light pointing up. Unfold the Snapgrid, place it over the VELVET diffuser and flip the elastics over the panel corners to secure it.

The side covers prevent emitting of spill light.
The Snapgrid produce a 40° beam angle.

**Included HEXAGONAL SPUD use**

You can place the Vlock, Gold mount or AC Power on any stand mast for a handy use close to the lamp head.

To do so you will need to use a regular Super Clamp (not included in the kit) and insert the Hexagonal 5/8" (16mm) baby spud.

Once installed the hexagonal spud, just slide the holder (located at the Vlock, Gold mount or AC Power) bottom over the spud plate until properly seated, as shown in the picture.

**NOTES**

To power the VELVET LED panel you need to use a VELVET XLR3 DC power extension cable, Ref: XLR3-DCC4.5m

SNAPGRID CLOTH FLAMEPROOF RATING

The Snapgrid has been manufactured with black cloth which meets the flameproof standards UNE EN 1101 and EN 13772

CHROMATIVITY COORDINATES DIAGRAM

(x, y CIE-1931)

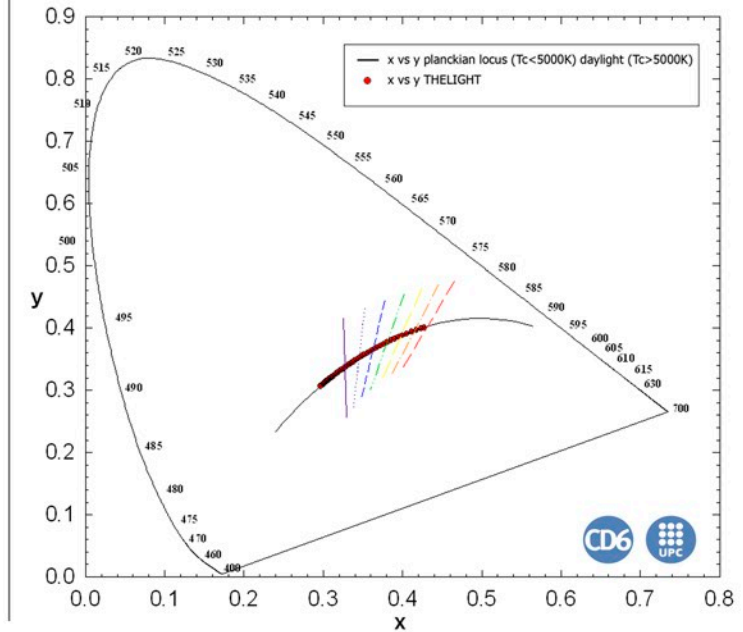

Shown on the diagram are the THELIGHT lamp head chromaticity coordinates (x, y CIE-1931) feed and digitally controlled by its Control Unit and they are compared with the reference illuminants. These reference illuminants are the Planckian locus radiator set below 5000K and the CIE daylight reference is set over 5000K. The Planckian locus radiator references the chromaticity for several tungsten lamps colour temperatures while the daylight locus typify daylight type D illuminants. The diagram evidence the light emanated by THELIGHT luminary at every colour temperature entirely matches with the described locus reference so that the colour of the light produced is essentially the same as incandescent and daylight. It is also remarkable the minimum green/magenta deviation over the locus reference along the range of colour temperatures (means minimal difference between THELIGHT chromaticity coordinates and the ideal reference line).

CALIBRATION

The Instrument Systems scanning spectrometer, model Spectro 320, serial number 30932004, with its accessory TOP-100 has been calibrated according to the United States National Institute of Standards (NIST) and the german Physikalisch-Technische Bundesanstalt (PTB) standard references.

ACCURACY

The Instrument Systems scanning spectrometer, model Spectro 320, serial number 30932004, with its accessory TOP-100 has an imprecision over the spectral radiometric results delivered lower than 1%.

Specifications subject to change without notice. THELIGHT technology is protected under Spanish license laws with international patents pending.
THELIGHT luminary for cine and tv, S.L. www.thelight.com.es

This equipment is designed to meet the following regulations and safety standards for battery powered technology equipment:

ENVIRONMENTAL

THELIGHT VELVET Light 1 & 2 devices are certified and intended for indoor or outdoor use (IP54)
LAMP HEAD OPERATION TEMPERATURE from -20° to +40° C
OPERATING HUMIDITY from 30 to 90% RH non condensing
DECLARATION OF CONFORMITY TO EMC DIRECTIVE 2004/108 EC

**MANUFACTURER
name & adress**

Thelight luminary for cine and tv, S.L.
Gorcs Lladó 1, nave 2. T08210 Barberá del Vallés. BARCELONA, SPAIN
info@thelight.com.es / www.thelight.com.es

Declares that the products:

MODELS

VELVET Light 1/ Light 2 BASIC/ VELVET Light 1/ Light 2 STUDIO

MANUFACTURED BY: Thelight luminary for cine and tv, S.L.
MANUFACTURED IN: Barberá del Vallés (BARCELONA) SPAIN
MARK: THELIGHT

COMPLY WITH THE **CE** DIRECTIVES:

GENERAL SECURITY: 2001/95/CE EN 60598-1:2003+A1: 2006
Luminaires: general requirements

DIRECTIVE: 2004/108/CE Electromagnetic Compatibility (E.M.C.)

ELECTROMAGNETIC COMPATIBILITY: THELIGHT is intended to
Electromagnetic Environment E2 (Commercial and light industrial).

STANDARDS

IEC 60598-1 Luminaires Part 1: General requirements and test
IEC 60598-2-17 Luminaires Part 2: Particular requirements section seventeen – luminaires for stage lighting, television and film studios (outdoor and indoor)
IEC 62031 LED modules for general lighting – Safety specifications
EN61547 Equipment for general lighting purposes – EMC immunity requirements
EN 61000-6-1:2005 Electromagnetic Compatibility, Generic immunity standard. Residential and light industry.
EN 61000-6-3:2005 Electromagnetic Compatibility, Generic EMI standard. Residential and light industry.
IEC EN61000-6-4:2005. Generic. Industrial environments emission (radiated)
EN 301489-1 v1.8.1(2008-02) Radio Electric Spectrum (1 – 6 GHz Band)
UNE-EN 55015:2007+A1:2008+A2:2009 EMI of electrical lighting and similar equipment (CISPR 15:2005)
EN 55015-1:2006 Lighting and similar equipment radioelectric radiation (conducted emissions, radiated current)

Barberá del Vallés, 7th January 2016



Javier Fdez. De Valderrama. Authorized Administrator

VELVET Light 1
IP54 protection

Weight: 3,5 kgs / 7,7 lbs. Power draw 75 W / 5,2 Amps at 14,4 VDC.

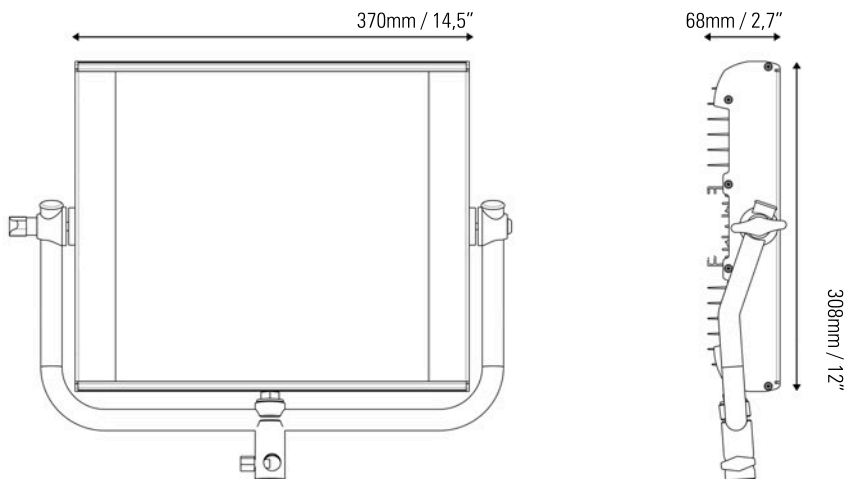

VELVET Light 2
IP54 protection

Weight: 6 kgs / 13,2 lbs. Power draw 150 W / 10,4 Amps at 14,4 VDC.

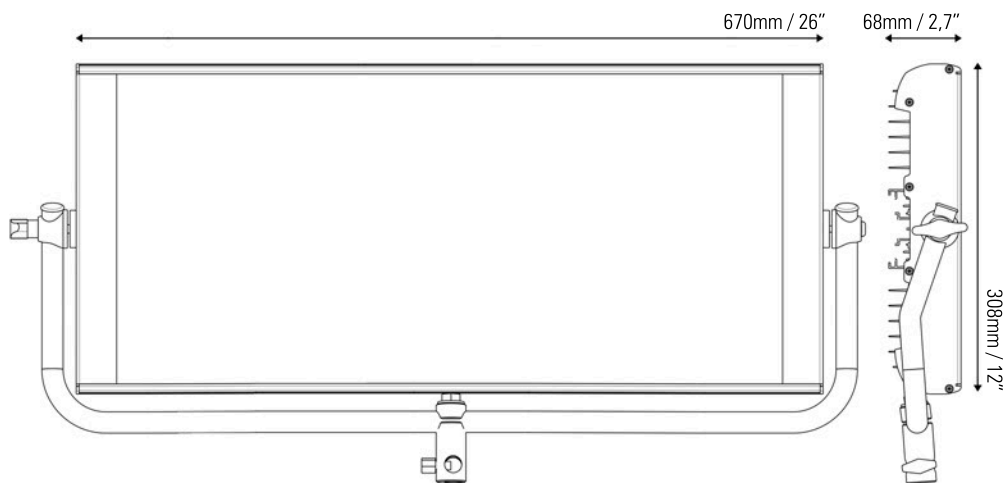

VELVET Light 1
IP51 protection

Weight: 3,5 kgs / 7,7 lbs. Power draw 75 W / 0,68 Amps at 110V DC.

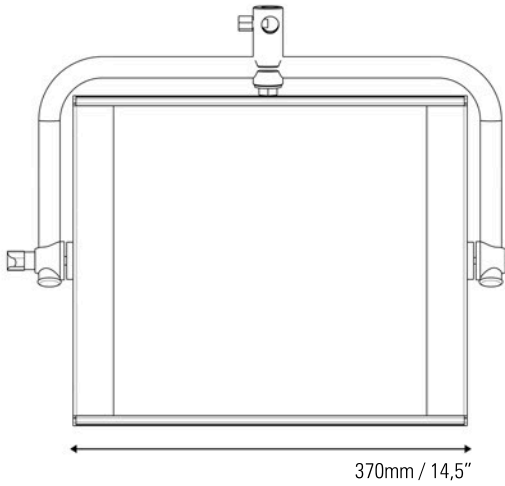
**VELVET Light 2**
IP51 protection

Weight: 6 kgs / 13,2 lbs. Power draw 150 W / 1,36 Amps at 110V DC.

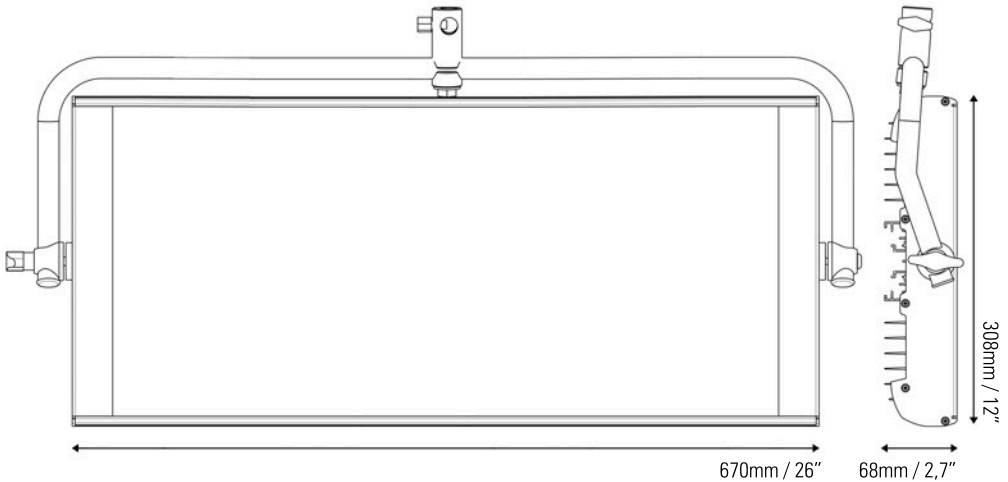

GENERAL WARRANTY

THELIGHT LED light equipments are guaranteed to be free from defects in workmanship and parts in a warranty period of two (2) years from the date of purchase. Defects that occur within this warranty period, under normal use and care will be repaired or replaced at THELIGHT discretion, solely at our option with no charge for parts or labour.

In the event of the equipment malfunction, contact the dealer from which you purchased the product. Please note that you will be not be reimbursed for the cost of bringing the equipment to the THELIGHT Repair Centre.

THELIGHT reserves the right to replace the product or relevant part with the same or equivalent product or part, rather than repair it. Where a replacement is provided the products or part replaced becomes the property of THELIGHT. THELIGHT may replace parts with refurbished parts. Replacement of the product or a part does not extend or restart the Warranty period.

RETURN POLICY

Returns or exchanges from the customers will be accepted within 15 days of delivery and will not include the actual shipping costs. Item(s) must be in original packaging and condition, must not be assembled, and must include its original user manual.

This warranty does not cover any damage resulting from:

- Failure to follow the instructions in the instruction manual Repair, modification or overhaul not conducted by any authorized THELIGHT personnel.
- Fire, natural disaster, act of God, lightning, abnormal voltage, etc;
- Submergence in water (flooding), exposure to alcohol or other beverages, infiltration of sand or mud, physical shock, or dropping of the equipment and other unnatural causes.

This warranty only applies to the LED panel and not to the accessories, such as barn doors or mounts.

Any consequential damages arising from failure of the equipment, such as expenses incurred in taking pictures or recording images or loss of expected profit, will not be reimbursed whether they occur during the warranty period or not.

Parts essential to the servicing of the light equipment (that is, components required to maintain the functions and quality of the fixture) will be available for a period of five years after the product is discontinued.

THELIGHT Luminary for cine and tv, S.L.
www.thelight.com.es

The total or partial reproduction of this guide is prohibited without the express written permission of THELIGHT.

THELIGHT technology is protected under Spanish license laws with international patents pending.

Information and specifications in this document are subject to change without notice.

Luminary for cine and TV, S.L.



VELVET Light 1/2 SERIES

www.thelight.com.es

2017. Copyright THELIGHT. All rights reserved